

Revised Record

1.0

New issue

2010-4-11

INTERFACE:

J1 (并口)		J2 (串口)	
1	VSS	17	VSS
2	VDD	18	VDD
3	VO	19	V0
4	RS	20	SCLK
5	/RW	21	SID
6	E	22	CS
7	DB0	23	LED-A
8	DB1	24	LED-K
9	DB2		
10	DB3		
11	DB4		
12	DB5		
13	DB6		
14	DB7		
15	LED-A		
16	LED-K		

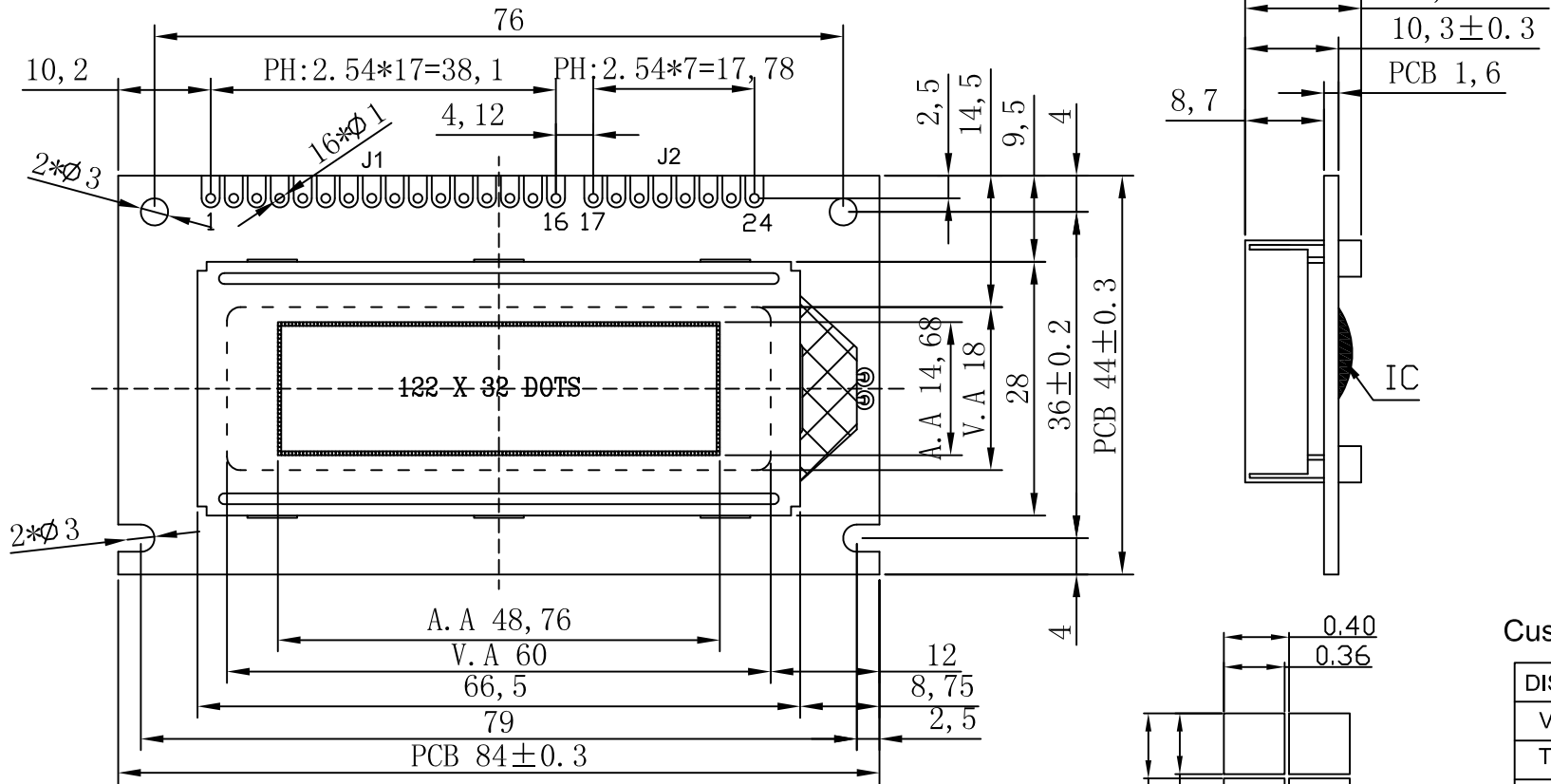

Customer's Choices:

DISPLAY TYPE:	
View angle:	
Temp:	
Voltage:	
IC:	
Backlight:	
Other:	

NOTES:

- 01. DISPLAY TYPE: STN-BLUE/NEGATIVE/TRANSMISSIVE RoHS
- 02. OPERATING VOLTAGE: VOP=4.8V, VDD=5.0V
- 03. OPERATING TEMPERATURE: -20°C~+70°C
- 04. STORAGE TEMPERATURE: -30°C~+80°C
- 05. DRIVE MODE: 1/32DUTY, 1/5BIAS
- 06. VIEWING DIRECTION: 6:00
- 07. DRIVE IC: AIP31020(OR-EQV)
- 08. CONNECTOR: ZEBER
- 09. BACKLIGHT: LED(WHITE)
- 10. CUSTOMER'S PART ID: BLAZE\_STANDARD\_PRODUCT

**BLAZE** Blaze Display Technology Co.,Ltd.

DESIGNED BY: BDT-20	BGB12232-10-SERIES	VERSION: 1.0
CHECKED BY: BDT-07		PAGE 1 OF 1
APPROVED BY: BDT-02		UNIT: mm
Website: <a href="http://www.blazedisplay.com">http://www.blazedisplay.com</a>		DATE: 2010-4-11